

INSTALLATION INSTRUCTIONS

COMBINATION SLIDING DOOR PULL AND LOCK

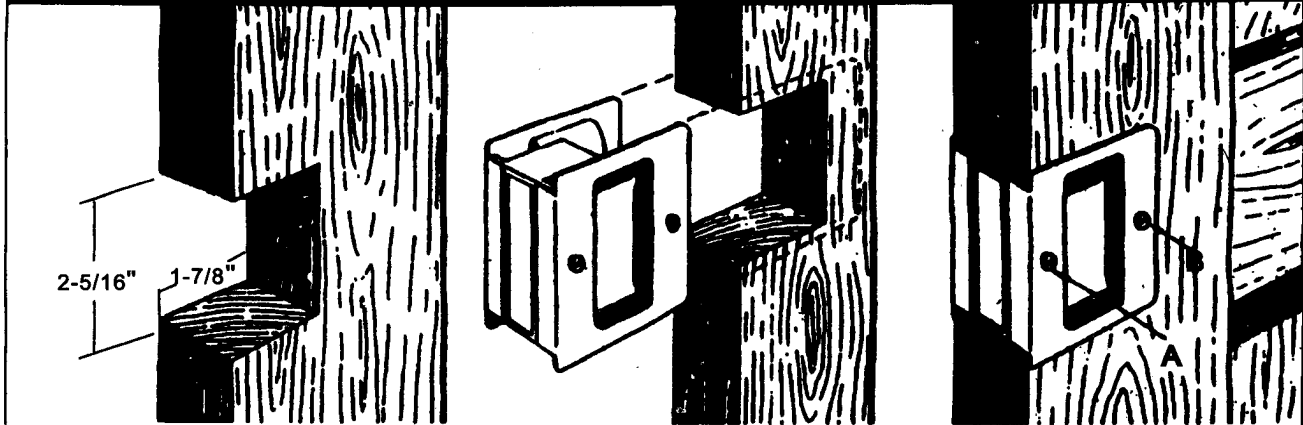

- 1 Cut one simple notch in door.
- 2 Slip pull into position as shown. Mark screw hole locations on door. Countersink to 5/16" dia.
- 3 Fasten side plates with wood screws(B). Align center section by loosening and tightening machine screws(A).

INSTALLATION OF STRIKE PLATE FOR LOCKING SET ONLY

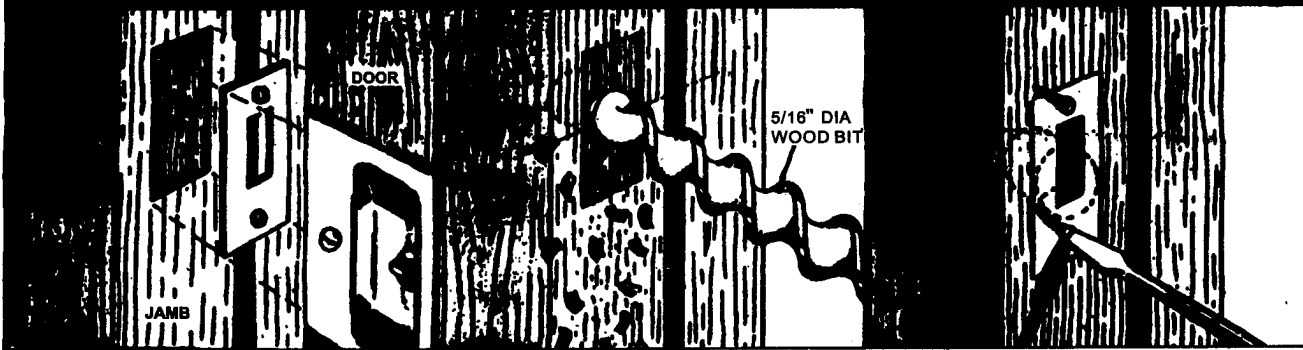

- 1 Mark and mortise strike on jamb to correspond to lock position on door.
- 2 Drill 15/16" diameter hole 1/2" deep in center of mortise.
- 3 Screw strike plate into position using #6 x 5/8" large flat head wood screws.

TO ASSEMBLE AFTER REVERSING PLATES

FOR 1-3/4" THICK DOORS

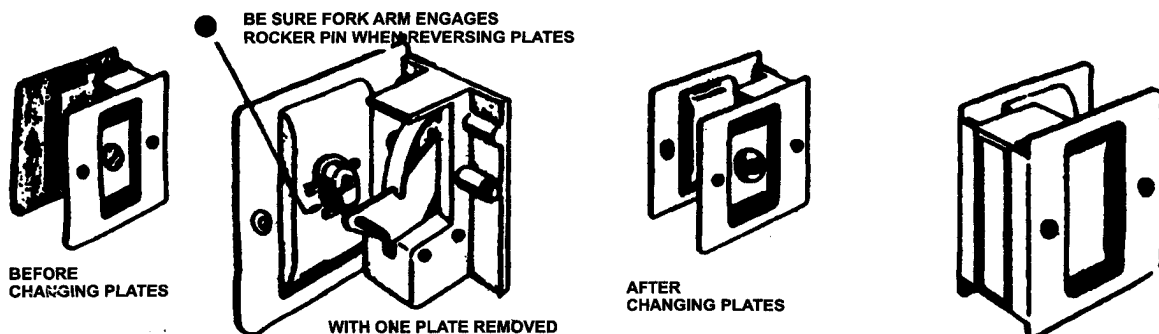

When it is desirable to reverse outside plates on lock assembly, first remove machine screw on each side - change plates from side to side (making sure that fork arm engages rocker pin) and re-assemble.

Back out machine screw on each side 3/16". then install per instructions.